

# C-Pace / C-Dish

## Cell Culture Stimulation System

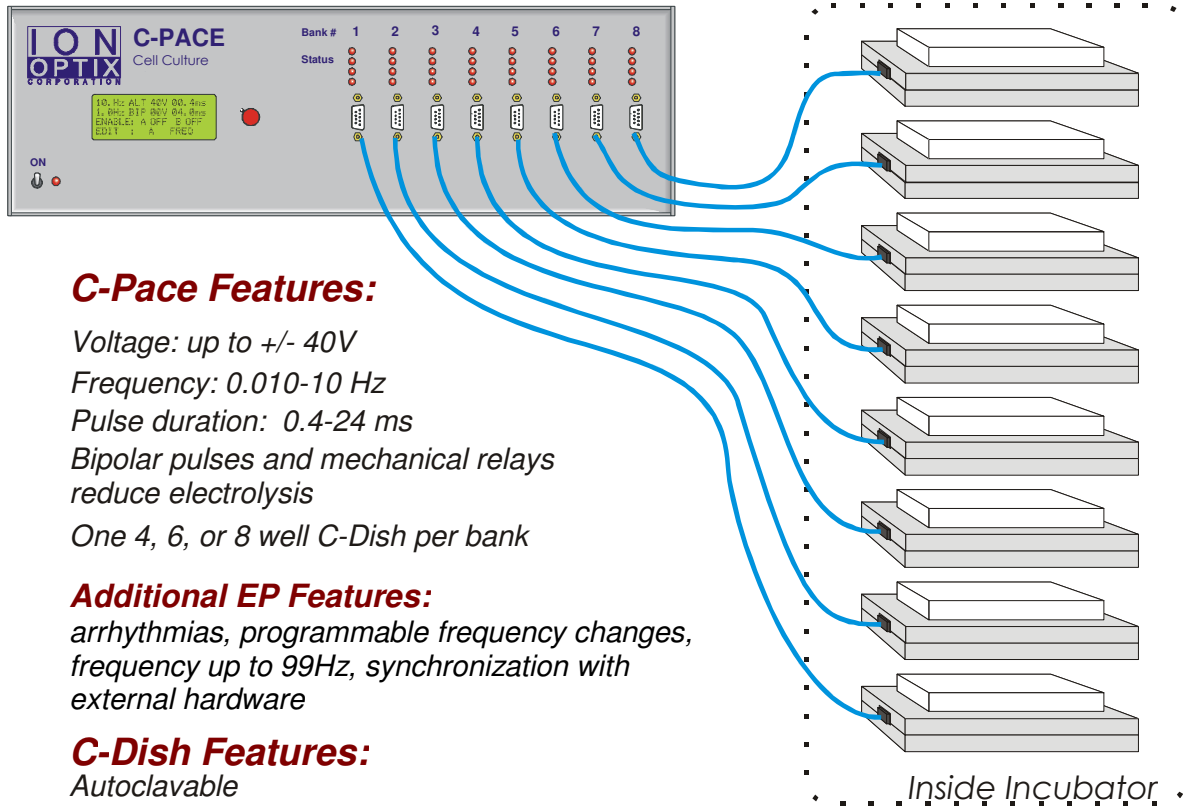

### **C-Pace Features:**

*Voltage: up to +/- 40V*

*Frequency: 0.010-10 Hz*

*Pulse duration: 0.4-24 ms*

*Bipolar pulses and mechanical relays  
reduce electrolysis*

*One 4, 6, or 8 well C-Dish per bank*

### **Additional EP Features:**

*arrhythmias, programmable frequency changes,  
frequency up to 99Hz, synchronization with  
external hardware*

### **C-Dish Features:**

*Autoclavable*

*Large surface area carbon electrodes prevent toxic buildup*

*Physically stable assembly fits standard multiwell culture dishes*

**The Culture Pacer System provides a comprehensive solution to improving the quality and increasing the experimental lifespan of myocyte and other excitable preparations.**

The C-Pace represents the first commercially available cell culture stimulator. Up to 8 output banks can generate +/- 40 V, bipolar pulses. Each bank is sufficient to stimulate a multiwell (4, 6, and 8 well C-Dishes are available) dish. The pulse characteristics (voltage, frequency and duration) can be configured separately for each bank.

The C-Dish is a culture dish electrode assembly that places large-surface area carbon electrodes into a standard multiwell culture dish. The entire assembly is safe to autoclave. The C-Dish is connected to the C-Pace via a single ribbon cable, which is thin enough to thread around an incubator door. The large surface area, pure carbon electrodes reduce the build-up of toxic waste products. Carbon has proved to be the superior material for electrodes, but only if soaked in distilled water very regularly. We are therefore recommending that users buy two electrode trays for every preparation, and plan to have one soaking while the other is in use.

# Overview of Chronic Pacing of Cells in Culture

Chronic electrical stimulation has been shown to prevent the dedifferentiation of myocytes that occurs in long term culture. Pacing will maintain the rod shaped, striated morphology of the myocyte for several days. Whereas quiescent cells begin losing their contractile properties within 6 to 18 hours, most chronically paced experiments run 72 hours with little loss of contraction amplitude. Protein synthesis is also maintained and cells kept in normal nitrogen balance for at least 72 hours. Effects have been studied out to 7 days. In a good adult rat myocyte preparation, the C-Pace/C-Dish system generally gets 70-80% capture (although there is some thought that only using enough voltage to stimulate 50-60% of the cells has the advantages of pre-selection and best maintenance of the healthiest cells). Use of the system, therefore, allows for experiments requiring several days and maximizes the number of cells, which can be used from each animal.

## The following is a partial list of relevant papers:

### C-Pace Reference:

Ahlers BA, Song J, Wang J, Zhang X, Carl L, Tadros G, Rothblum L, Cheung J, Effects of sarcoplasmic reticulum  $Ca^{2+}$  - ATPase overexpression in postinfarction rat myocytes. *J. Applied Physiology* 2005: in press. ePub  
doi:10.1152/jappphysiol.00013.2005

### Culture Pacing References:

Berger H. J., Prasad S. K., Davidoff A. J., Pimental D., Ellingsen O., Marsh J. D., Smith T. W., Kelly R. A. Continual electric field stimulation preserves contractile function of adult ventricular myocytes in primary culture *Am J Physiol Heart Circ Physiol* 1994; 266: H341-H349.

Ellingsen O, Davidoff A, Prasad S, Berger H, Springhorn J, Marsh J, Kelly R, Smith T. Adult rat ventricular myocytes cultured in defined medium: phenotype and electromechanical function. *Am. J. Physiol. Heart Circ Physiol* 1993; 265: H747-H754.

Holt E, Lunde PK, Sejersted OM, Christensen G. Electrical stimulation of adult rat cardiomyocytes in culture improves contractile properties and is associated with altered calcium handling. *Basic Res Cardiol.* 1997 Oct;92(5):289-98.

Ivester CT, Kent RL, Tagawa H, Tsutsui H, Imamura T, Cooper G 4th, McDermott PJ. Electrically stimulated contraction accelerates protein synthesis rates in adult feline cardiocytes. *Am J Physiol.* 1993 Aug;265(2 Pt 2):H666-74.

Johnson TB, Kent RL, Bubolz BA, McDermott PJ. Electrical stimulation of contractile activity accelerates growth of cultured neonatal cardiocytes. *Circ Res.* 1994 Mar;74(3):448-59.

Kato S, Ivester CT, Cooper G 4th, Zile MR, McDermott PJ. Growth effects of electrically stimulated contraction on adult feline cardiocytes in primary culture. *Am J Physiol.* 1995 Jun;268(6 Pt 2):H2495-504.

Mann DL, Kent RL, Cooper G 4th. Load regulation of the properties of adult feline cardiocytes: growth induction by cellular deformation. *Circ Res.* 1989 Jun;64(6):1079-90.

McDonough, P. M., and Glembofski, C. C. 1992. Induction of atrial natriuretic factor and myosin light chain-2 gene expression in cultured ventricular myocytes by electrical stimulation of contraction. *J. Biol. Chem.* 267:11665-11668.

McDonough, P. M., Stella, S. L., and Glembofski, C. C. 1994. Involvement of cytoplasmic calcium and protein kinases in the regulation of ANF secretion by contraction rate and endothelin. *J. Biol. Chem.* 269:9466-9472.

McDonough, P. M., Hanford, D. S., Sprenkle, A. B., Mellon, N. R., and C. C. Glembofski. 1997. Collaborative Roles for JNK, c-Jun, Serum Response Factor, and Sp1 in Ca-regulated Myocardial Gene Expression. *J Biol. Chem.* 272, 24046-24053

R. V. Yelamarty, R. L. Moore, F. T. Yu, M. Elensky, A. M. Semanchick, and J. Y. Cheung. Relaxation abnormalities in single cardiac myocytes from renovascular hypertensive rats. *Am J Physiol Cell Physiol.* April 1992 262: C980-C990

Song J, Zhang X, Carl L, Qureshi A, Rothblum L, Cheung J. Overexpression of phospholemman alters contractility and  $[Ca^{2+}]$  transients in adult rat myocytes. *Am J Physiol Heart Circ Physiol* 2002 May; 283: H576-H583.

Tadrow G, Zhang X, Song J, Carl L, Rothblum L, Tian Q, Dunn J, Lytton J, Cheung J. Effects of  $Na^+/Ca^{2+}$  exchanger downregulation on contractility and  $[Ca^{2+}]$  transients in adult rat myocytes. *Am J Physiol Heart Circ Physiol.* 2002 June; 283 H1616-H1626.

Zhang XQ, Song J, Rothblum LI, Lun M, Wang X, Ding F, Dunn J, Lytton J, McDermott PJ, Cheung JY. Overexpression of  $Na^+/Ca^{2+}$  exchanger alters contractility and SR  $Ca^{2+}$  content in adult rat myocytes. *Am J Physiol Heart Circ Physiol.* 2001 Nov;281(5):H2079-88.